

Horizontal Post Insulator Properties

Jeffrey Miller, P.E.
JAMCS Corporation

PLS-CADD User's Group Meeting

July 14 – 16, 2009

Madison, WI

- Typically engineers are concerned with 3 things when evaluating a post insulator.
 1. Vertical Load
 2. Transverse Load
 3. Longitudinal Load
- Can not use just one of these to determine if a post insulator is adequate for the anticipated loads.
- All 3 loads and their interactions should be used in the evaluation.

NESC Considerations

- Rule 277. Mechanical Strength of Insulators

Insulators shall withstand all applicable loads specified in Rules 250, 251, and 252 except those of Rule 250C and Rule 250D without exceeding the following percentages of their strength rating for the respective insulator type shown in Table 277-1.

Proper allowance should be made for the loads in Rule 250C and Rule 250D.

(Rules 250, 251, and 252 do **NOT** specify load factors. These are covered in Rule 253. Therefore the strength factors in Table 277-1 are to be used under the weather conditions noted in Rules 250, 251, & 252 WITHOUT any load factors applied.)

NESC Table 277-1

Allowed percentages of strength ratings

Insulator Type	Percent	Strength Rating ¹	Reference Standard
Ceramic			
Suspension	50%	Combined mechanical and electric strength	ANSI C29.2-1992
Line post	40% 50%	Cantilever strength Tension, compression strength	ANSI C29.7-1996
Station Post	40%	Cantilever, tension, compression or torsion strength	ANSI C29.9-1983 [B8]
Station Cap and Pin	40%	Cantilever, tension, compression or torsion strength	ANSI C29.8-1985 [B7]
Non-Ceramic			
Suspension	50%	Specified mechanical load (SML)	ANSI C29.12-1997 [B11] and C29.13-2000 [B12]
Line post	50%	Specified cantilever load (SCL) or specified tension load (STL)	ANSI C29.17-2002 [B13] and C29.18-2003 [B14]
Station Post	40%	All strength ratings	

- Manufacturers do not directly provide ultimate load capacities of their post insulators.
- Typically they provide:
 - MDCL (Maximum Design Cantilever Load) or RCL (Rated Cantilever Load)
 - SCL (Specified Cantilever Load)
 - RTL (Rated Tensile Load)

SCL

- Specified Cantilever Load
- Typically the ultimate vertical load of the insulator.

MDCL

- Maximum Design Cantilever Load
- Typically approximately $\frac{1}{2}$ of the SCL or ultimate load.
- Assumes a load factor of 1.0 is used.

STL

- Specified Tensile Load
- Typically the ultimate tensile load of the insulator.
 - Usually the value shown is the load that puts the post in tension (away from the pole).
 - The compression (in towards the pole) is usually not shown.

RTL

- Rated Tensile Load
- Typically approximately $\frac{1}{2}$ of the specified tensile load (STL).
- Assumes a load factor of 1.0 is used.

Since most manufactures will only provide the MDCL and RTL, you need to increase these according to the manufacturer's notes to get the SCL and STL in order to use the strength factors listed in NESC Table 277-1.

Your insulator component file should reference the ultimate loads of the insulator.

Your criteria file should then be set up using the Strength Factors in NESC Table 277-1 and Load Factors = 1.0 for NESC Rule 250 Loads.

PLS-POLE

Post Insulator Component File

Part 1

	Label	Stock Number	Has Brace	Horz. Projection (ft)	Vert. Projection (ft)	Weight (lbs)
1	NGK 69KV	NGK-L2-SN211-13	No	3.52	-0.75	57.6
2	NGK 69KV BRACED	NGK-L2-SN211-13/251SS320YJ	Yes	3.52	-0.75	81.8
3	NGK 115KV	NGK-L2-SN361-13	No	5.325	-1.11	71.2
4	NGK 115KV BRACED	NGK-L2-SN361-13/251SS450YJ	Yes	5.325	-1.11	85
5	NGK 161KV	NGK-L2-SN471-13	No	6.65	-1.41	81.1
6	NGK 161KV BRACED	NGK-L2-SN471-13	Yes	6.65	-1.41	97.6
7	LAPP 69kV	LAPP-CL2-044-21-082-A	No	3.66667	-0.7794	74.3
8	LAPP 69kV BRACED	LAPP-CBP2-044-082-01	Yes	3.66667	-0.7794	90.4
9	LAPP 115kV	LAPP-CL2-064-21-138-A	No	5.33333	-1.13	87.3
10	LAPP 115kV BRACED	LAPP-CBP2-064-138-02	Yes	5.33333	-1.13	105.7
11	LAPP 161kV	LAPP-CL2-080-21-180-A	No	6.66667	-1.42	97
12	LAPP 161kV BRACED	LAPP-CBP2-080-180-01	Yes	6.66667	-1.42	113
13						

PLS-POLE

Post Insulator Component File

Part 2

	Label	Interaction Capacity	Cantilever Capacity (lbs)	Tension Capacity (lbs)	Comp. Capacity (lbs)	Long. Stiffness (lbs/ft)	Vert. Stiffness (lbs/ft)
1	NGK 69KV		4320	15000	15000	0	0
2	NGK 69KV BRACED	Edit (215 points)	0	0	0	0	0
3	NGK 115KV		2750	15000	15000	0	0
4	NGK 115KV BRACED	Edit (215 points)	0	0	0	0	0
5	NGK 161KV		2150	15000	15000	0	0
6	NGK 161KV BRACED	Edit (208 points)	0	0	0	0	0
7	LAPP 69kV	Edit (134 points)	0	0	0	0	0
8	LAPP 69kV BRACED	Edit (239 points)	0	0	0	0	0
9	LAPP 115kV	Edit (121 points)	0	0	0	0	0
10	LAPP 115kV BRACED	Edit (226 points)	0	0	0	0	0
11	LAPP 161kV	Edit (115 points)	0	0	0	0	0
12	LAPP 161kV BRACED	Edit (195 points)	0	0	0	0	0
13							

MANUFACTURER'S COMBINED LOADING CHART

VS

PLS INTERACTION DIAGRAM

(using 115 kV Line Post and Braced Line Post)

Typical Manufacturer's Combined Loading Charts

- Available for both braced and **unbraced** line post insulators.
- Should use the combined loading chart for unbraced insulators not just the MDCL and STL. Combined loading charts take into account the longitudinal loading and the interaction with the cantilever and tensile loading. Most manufacturers only provide the tensile strength of the insulator and **not the compressive strength** unless the Combined Loading Chart is requested.

Typical Manufacturer's Combined Loading Charts

- Combined loading charts for braced line post insulators should take into account the connection hardware for a correct loading chart.
- Some manufacturer's won't provide a chart with the hardware limitation because they don't provide complete assemblies.

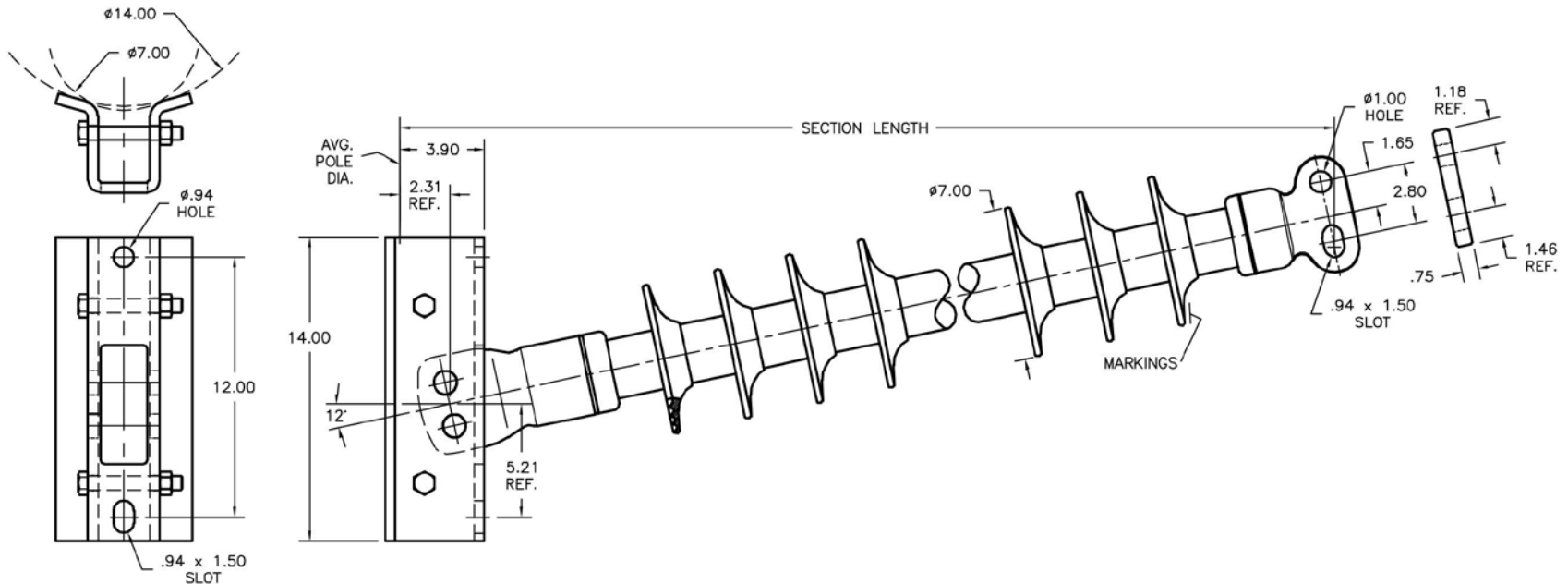

Physical Characteristics

Section Length, in.	64.00
Creepage Distance, in.	140.31
Dry Arcing Distance, in.	51.65
Weight Approx., lb.	81.68

Mechanical Load Values

Specified Cantilever Load (SCL), lb.	2928
Reference Cantilever Load (RCL), lb.	1464
Deflection at RCL, in.	8.89

Voltage Values

50% Lightning Impulse Flashover, Pos., kV	836
50% Lightning Impulse Flashover, Neg., kV	886
Power Frequency Flashover, Wet, kV	495
Power Frequency Flashover, Dry, kV	568

Components (Qty. = 1)

1. Insulator w/ Mounting Base

Notes

1. Insulator Material: HTV Silicone / Fiberglass Core.
2. Ferrous Parts Are Hot Dip Galvanized.
3. Dimensions Are In Inches.
4. Tolerances As Per ANSI.
5. Testing As Per ANSI.



COMBINED LOAD CHART

UNBRACED LINE POST, 2.0 SF, RCL= WORKING LOAD

CL2-064-21-138-A

- LONGITUDINAL LOAD= 0 lb
- - - LONGITUDINAL= 300
- - - - LONGITUDINAL= 600
- LONGITUDINAL= 900

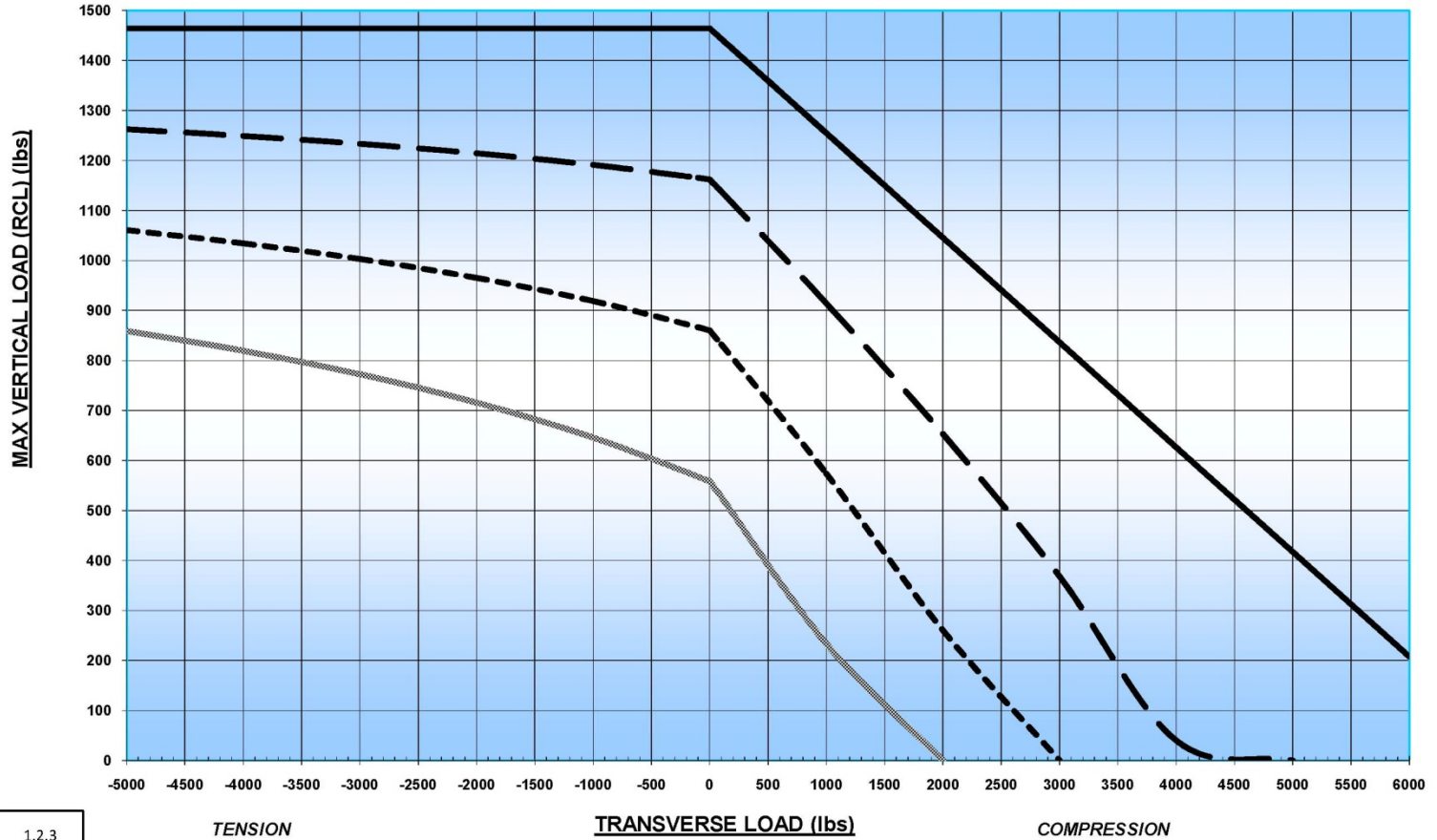

1.2.3

NGK

Unbraced Line Post

Combined Load Chart for L2-SN361-13 and -18

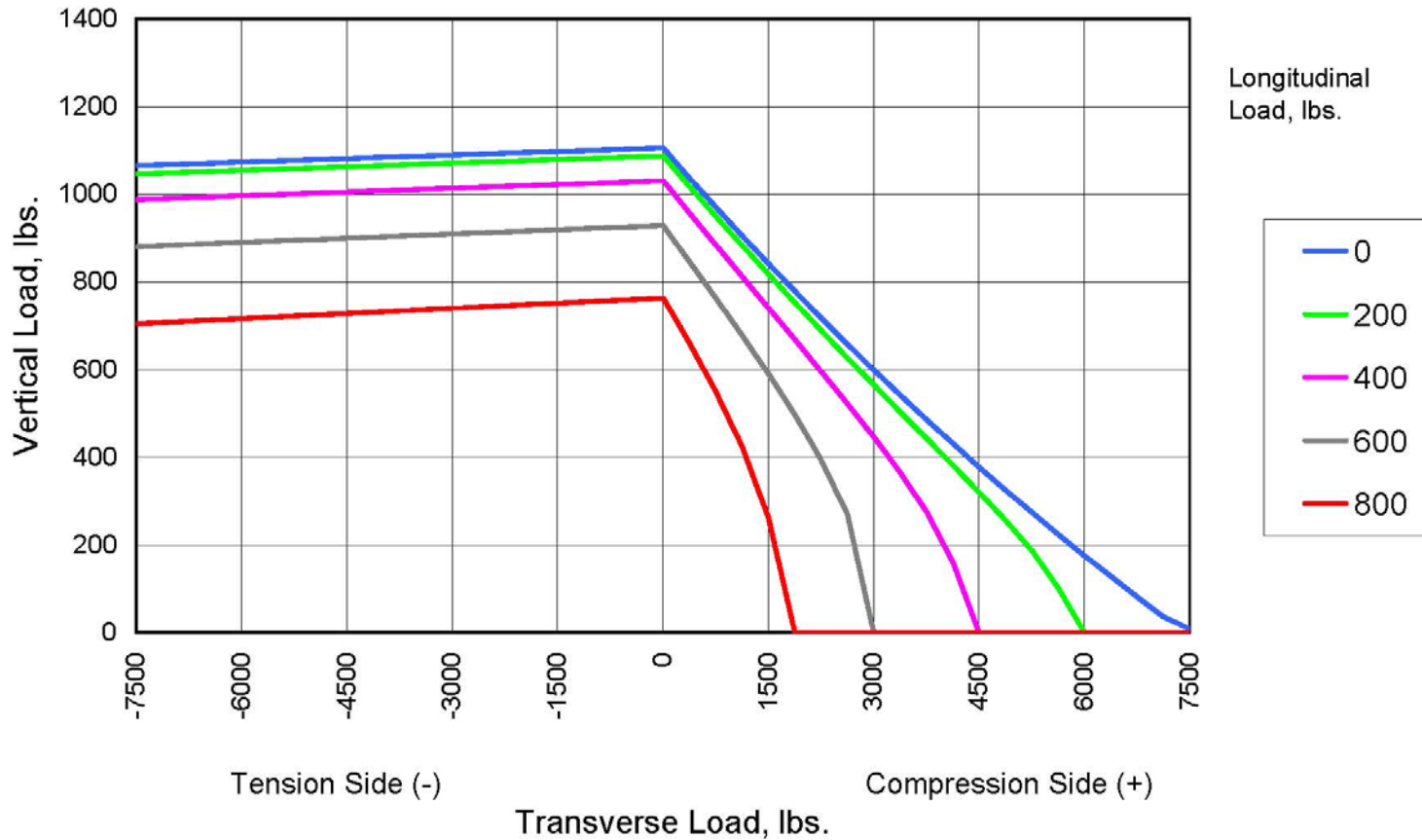

Note: These curves show the combined loads which equal to the MDCL (40% SCL).



COMBINED LOAD CHART

BRACED LINE POST, 2.0 SF, F_v = WORKING LOAD

CBP2-064-138-02

- POST LIMIT (0 LONG)
- MINIMUM LOAD
- LONGITUDINAL= 600
- LONGITUDINAL= 1000
- BRACE LIMIT
- CONNECTING HARDWARE LIMIT
- LONGITUDINAL= 800

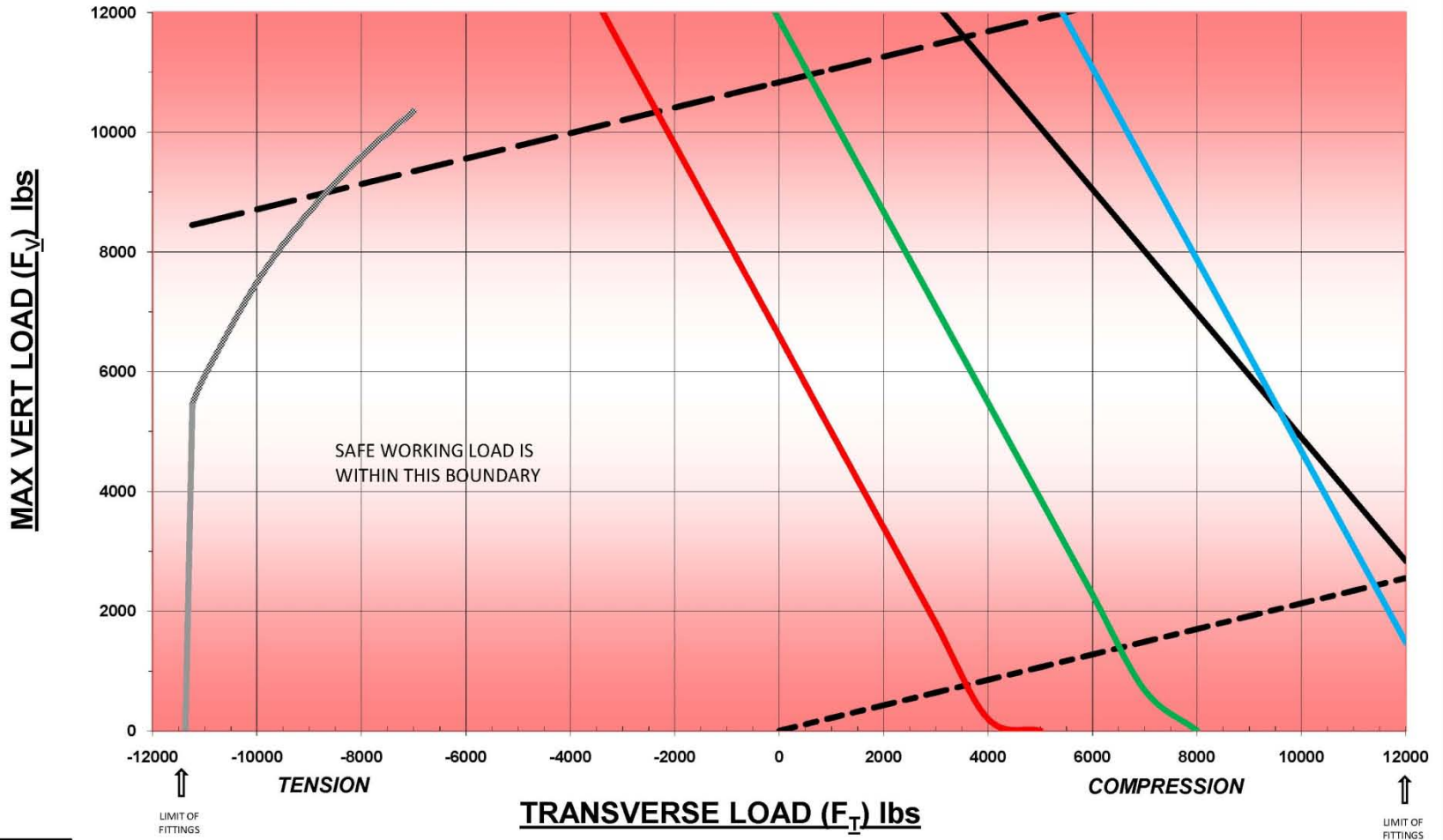

1.2.3

NGK

Braced Line Post w/o Hardware Limitations

Combined Load Chart

Strut: L2-SN361-13 / Stay: 25 Kip Sus. (Angle Alpha:12, Beta:57)

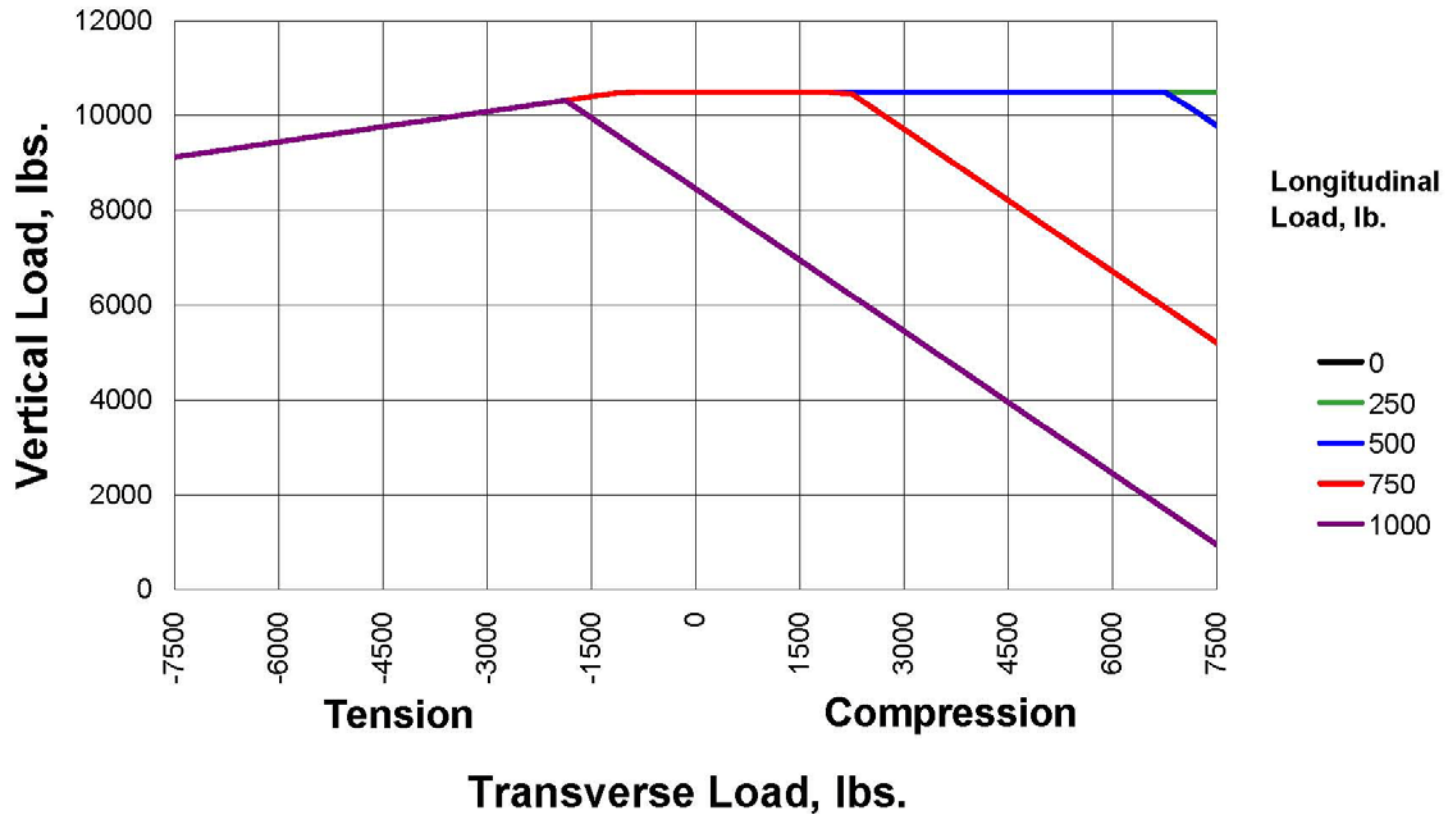

Note: These curves show the combined loads which are not greater than 50% or less of the design ultimate stress. The numerical simulations were implemented on the premise that the transverse load towards pole (compression load) faces to the pole.

PLS INTERACTION DIAGRAMS

- Differences between typical manufacturer's Combined Loading Chart and the PLS Interaction Diagram.
 - Tension and Compression forces are shown opposite. So the PLS Interaction Diagram will appear backwards to the manufacturer's Combined Loading Chart.
 - To create the PLS Interaction Diagram you need to scale the manufacturer's combined loading chart or request the raw data file used to create the combined loading chart.

PLS INTERACTION DIAGRAMS

- Things to consider when creating Interaction Diagram within PLS-POLE.
 - Compression force is negative value.
 - Tensile force is positive value.
 - Vertical force is typically down and positive value.
 - Longitudinal load is positive value.

PLS INTERACTION DIAGRAMS

- You can create multiple interaction curves for an insulator. These are separated by the different longitudinal loads.
- Interaction diagrams are CLOSED curves that run counter-clockwise, and START and STOP at the same point.
 - You can NOT have bulges away from the closed curve as shown in the manufacturer's Combined Loading Chart.
- Examples of PLS Interaction Diagrams:

LAPP

Unbraced Line Post

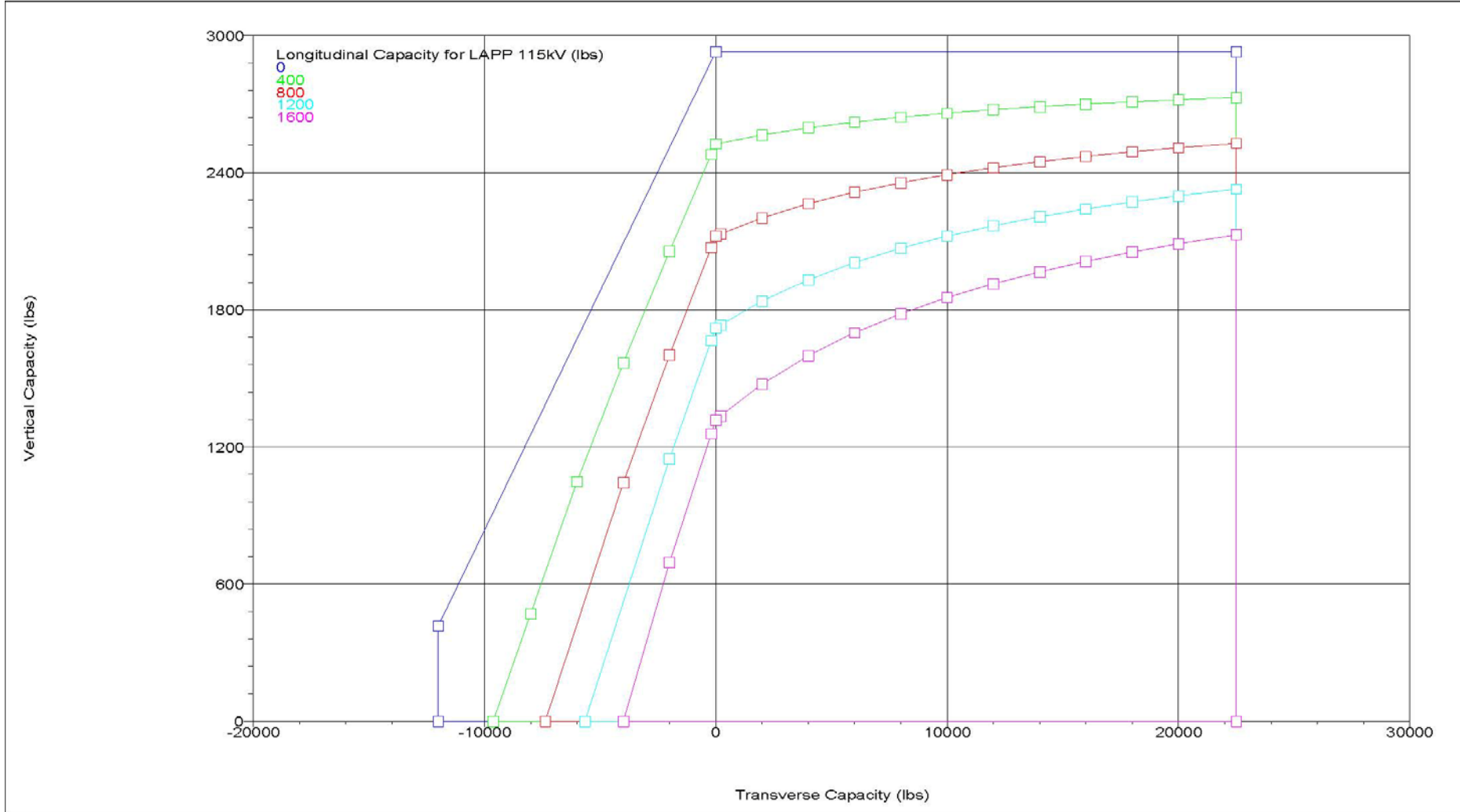

LAPP

Braced Line Post

JAMCS Corporation, Project: "tp-115xb_c"
PLS-POLE Version 10.02, 2:55:55 PM Wednesday, July 08, 2009

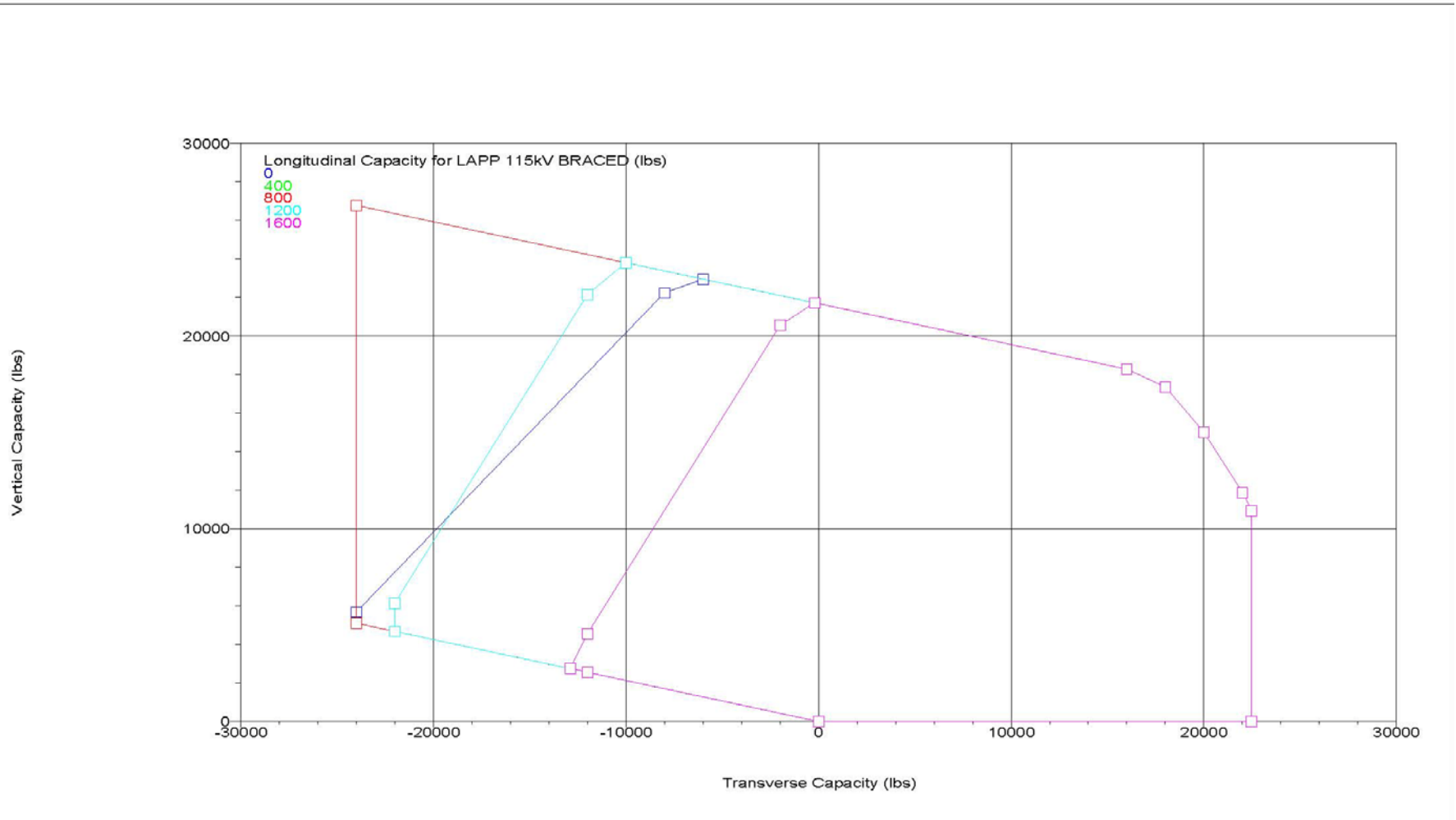

NGK Braced Line Post

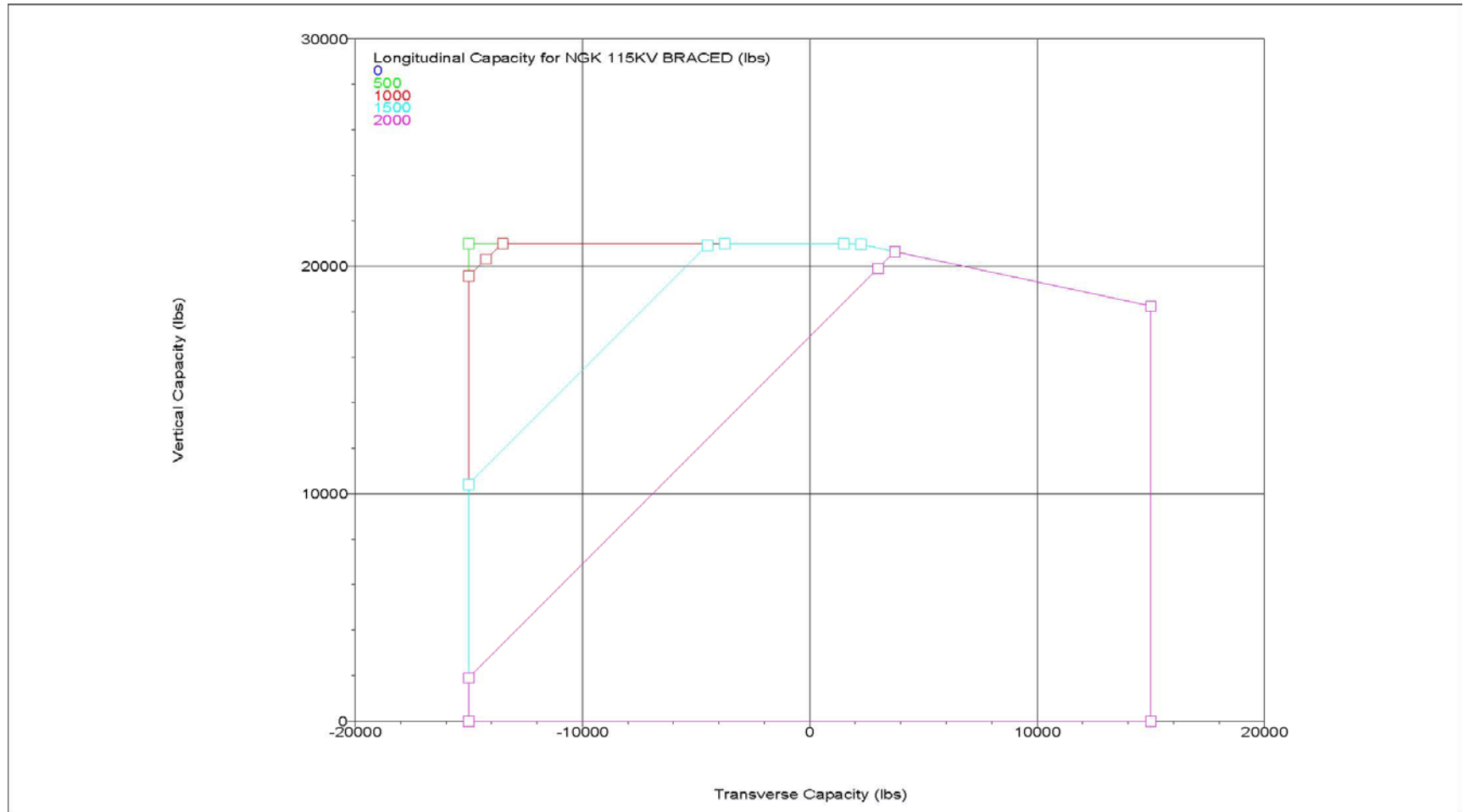

Analysis Results

- PLS-POLE uses the interaction curve that best fits the calculated loads.
- The % usage reported is not necessarily the percentage of the ultimate strength of the insulator, but of the interaction curve chosen. So don't get overly concerned about the % usage reported as long as it is less than 100%.
- Discussion...